

Powered Wheelchairs

Model #: _____
Serial #: _____
Date: _____

Provider Name: _____
Phone #: _____
Contact Person: _____

Setting up your equipment:

- Powered wheelchairs come in various makes, models and sizes. All models have distinct operating and driving controls. Do not attempt to change any settings or adjustments to the chair or any of its components without consulting your dealer.
- Assembly, initial charging and testing of your powered wheelchair will be done by the dealer prior to final delivery.
- Make sure that all equipment received is exactly what was ordered and/or prescribed.
- Final adjustments to front riggings, seat, back and all control functions will be done with the client, caregiver (if applicable) and as many members of the care team available. All adjustments are made with the client's well being, doctor's orders and client's living and working environment in mind. These adjustments will maximize your comfort and operating confidence.

Using your equipment:

- Check to make sure the power is OFF before transferring into the chair.
- All power function adjustments will be made after all mechanical adjustments are completed. This allows for client comfort and confidence before actual driving.
- The safety belt (if supplied) should be used at all times while seated in the chair.
- Make sure the battery charger is unplugged before attempting to drive.
- Drive control functions need to be set at their lowest possible operating levels for the first driving experience. This is a good time to check the living environment for any safety hazards or problem areas. Come up with alternate plans to alleviate the hazards and obstacles. Fine-tuning and adjustments to the drive controls will be made as the client becomes more and more comfortable with driving. These adjustments can only be made by your qualified dealer.

Frequent replacement items:

- Tires, tubes and air pressure are all items that need to be checked periodically. Advise your dealer of any abnormal wear and tear on these items.

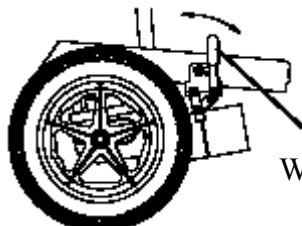
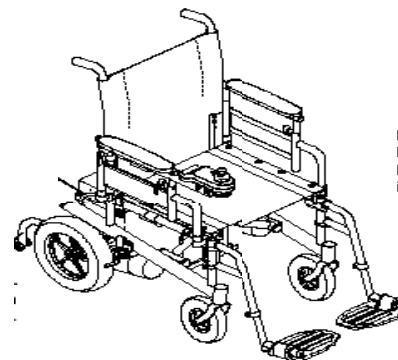

Diagram 1

Wheel lock handle



Maintenance:

- Other than possible tire inflation, all mechanical and electrical maintenance should be preformed by your qualified dealer.
- Normal user maintenance should include the following:
 - Keep your chair clean and out of harsh elements as much as possible. Rain and car washes can cause serious damage to your chair's electrical components.
 - Whenever new batteries are installed, they must be fully charged prior to use. Battery charging is your responsibility and should be done according to the battery manufacturers instructions, your dealer's instructions and according to your level of driving. Heavier use of your chair will require more frequent charging.
 - Installation of new batteries should only be performed by a qualified dealer.

Special Procedures:

- Always consult your dealer if there are any changes in your condition, living or working environment or your transportation needs.
- Disassembly and transportation of your chair varies drastically between makes and models. Make sure you understand all these procedures as your dealer has instructed and demonstrated. If you have any questions, please call your dealer. **DO NOT ATTEMPT TO DISASSEMBLE OR TRANSPORT YOUR CHAIR IF YOU ARE UNSURE OF THESE PROCEDURES.**
- Be conscious of your schedule for chair use. If you know in advance that you will be using your chair for a great length of time on any given day, be sure to have fully charged batteries before you depart.

Safety Issues:

- Never operate this chair for the first time without the proper training and instruction from your qualified dealer.
- Never allow anyone else to operate your chair.
- Never allow anyone else to perform any type of mechanical or electrical maintenance other than your qualified dealer.
- Always make sure that the power switch is in the OFF position before transferring into or out of the chair.
- Secure the safety belt (if one has been supplied) before attempting to operate the chair. Keep this belt secured at all times while seated.
- Parking or transferring in or out of the chair while on an incline is not recommended.
- If your chair comes equipped with anti-tipper devices, do not remove them. Removal of these parts could cause the chair to be unstable on inclines and over thresholds and curbs.
- Beware of slippery driving surfaces. They can cause a lack of traction for the chair and are also very unsafe for transfers. Try to avoid wet grassy areas, snow, ice and loose materials (such as gravel).
- Operate this chair on ramps and wheelchair lifts only with proper instruction and supervision.
- For detailed instructions on your chair's electronics and mechanical systems, refer to the Owner's Manual from the Manufacturer.
- Always call your dealer for all battery maintenance other than normal charging.

Please contact your equipment provider for any questions, adjustments, or repairs.

Your local provider:



©Copyright The VGM Group 2002
B.L.U.E. Sheet photos, drawings, and text courtesy of
Golden Technologies, Invacare, Leisure-Lift, Permobil,
Puritan Bennett, Pride, Respironics, Ross,
Sammons Preston, Smith-Nephew, Sunrise Medical